

# BACKFIRE

Volume 49 No 11 March 2016

**Club meetings:**  
7.30pm 2<sup>nd</sup> Tuesday each month.

**Club rooms:**  
Geelong Showgrounds  
79 Breakwater Rd East Geelong.



[www.wdhvcgeelong.com.au](http://www.wdhvcgeelong.com.au)



## CONTENTS

HONORARY OFFICE BEARERS AND COMMITTEE - 2015/2016.....	2
CONTENTS .....	3
PRESIDENTS REPORT.....	3
GENERAL MEETING MINUTES .....	4
GENERAL MEETING MINUTES (CONTINUED) .....	5
AGM & MEMBERSHIP NOTICES .....	6
AgVANTAGE UAV TALK .....	6
WORLD'S WORST CARS? .....	7
CALENDAR OF EVENTS .....	8
CALENDAR OF EVENTS .....	9
FEDERATION REPORT & NOTICES .....	10
Article –ELECTRIC MOTOR REPAIR .....	11
RALLY REPORTS .....	12
BAY CITY SWAP MEET .....	13
Article –HEARD OF A BRADFORD? .....	13
WDHVC MEMBER PROFILE .....	14
MARS BAR COMPETITION .....	15
FEBRUARY TINKER DAY REPORT .....	15
SALES, WANTED & CLUES .....	15
CALENDAR .....	16



## PRESIDENT'S REPORT

Greetings Members,

This month has seen our club having to adopt the recent changes to red plate conditions. This has caused some discomfort for some, however, it has to be.

A reminder to all ladies of the club not to miss the up-coming Ladies' Day planned for Sunday 28th February at a surprise, delightful venue with a very interesting speaker. Men driving their ladies to this event are welcome to enjoy a sausage sizzle and shed chin-wag at my place. Names for this special event can be given to Sean Murphy- 5298 1476 or 0401 743 776.

Keep in mind the Sea Sick Rally day on March 6th. Volunteers to collect and return visitors to the ferry at Queenscliff are asked to contact Cheryl Elliot on 0412 767 928 or 5248 0734.

A final opportunity to inspect the shearing shed at Lara will be offered on March 10, leaving the club rooms at 10:15am.

*Thought for the day - 'Learn to say no to the good, so you can say yes to the great.*

*- John Mason.*

Cheers,

John





## **VEHICLE PERMITS / REGISTRAR:**

Gus reminded members you have to be financial to be able to have RPS.

## **EDITOR:**

Libby said she had Jon Breedveld helping her to do the newsletter which was a big help, and could members please send in reports.

## **CRAFT NIGHT:**

Linda said the group did quilling last month which was very interesting, they always do something different and invited people to come and join in. Next month there will be gearboxes out the back for the men.

## **RALLY DIRECTOR :**

Sean reminded everyone of upcoming events and asked people to fill in the sheets for attending events.

## **LONG DISTANCE RALLY:**

Sharyn said that the New Zealand trip was now open to family and friends, but regardless of numbers the trip was still on and invited members to come to the information night. A long distance rally will probably be organised for Sept / Oct.

## **RALLY REPORTS:**

**Waterfront** – Sharyn said there was a good turn up and it was a great day – Max McKenzie said Jeanette dropped her phone where she was sitting and it fell through the slats so he had to go home and get screwdrivers to remove 8 screws to get it out – high light of his day

Australia day Rippleside park – Ken advised they had 12 cars and they have been asked to do it again next year.

**Smell the Roses** – Ray told how 6 bikes rode to Portarlington for lunch, then explained what they were doing next time.

**Federation Picnic** - \$25 admission if not a member.

**Museum** – David Koch commented how the Gippsland RS Valiant club were impressed with the car museum and he was impressed with and newsletter, perhaps committee could look at up grading ours.

**Seasick Rally** – Cheryl asked that members attending please bring extra chairs and thermos and come and meet other car enthusiasts.

## **GENERAL BUSINESS:**

Working bee - April.

RGAPS Bob Thompson advised on the resignation and temporary replacement.

Harold asked if renewal form was for red plates only – at moment.

Ray Matthews talked in detail on the tent site at Bendigo club has been doing this for 40yrs.

Max Mc Kenzie asked if people send mail to the club could they please put Sec. Treas.etc. on envelope.

Ken Parry went to Bendigo swap on the Sunday and a lot of stalls were not operating saying going Sunday was a waste of time.

Pres. John informed us that Cobden Engine Club has bought our old chairs and that the new ones stack easily.

John advised members that to have a car on **RPS you must be a paid up member of the club, this meaning if a wife has a car in her name she has to pay membership as well.**

Ray M asked for explanation of this ruling.

John asked if there was enough interest to hire a bus to go to Bendigo to see the Marilyn Monroe statue Committee nomination forms to be in the next Backfire, **and all nominations to be handed to secretary by the close of March meeting.**

For sales and wanteds were discussed some being – Harold sold listed *Backfire* items – Graham sold his Stag.

**Mars Bar Competition** – Graham Pocock was the delightful child and as no one guessed he got the Mars Bar

Meeting closed at 9.40pm - **next meeting to be held at 7.30pm on 8<sup>th</sup> March** in the clubrooms.



# Annual General Meeting

## PLEASE NOTE

The Annual General Meeting of the W.D.H.V.C. will be held on 12<sup>th</sup> April 2016, following the normal meeting starting at 7.30pm.

Members are requested to bring a plate of supper.

**Nominations for the committee and office bearers must be handed in by the end of the March Meeting.**

Fred Harris  
Secretary

## Membership Fees are Due

### VERY IMPORTANT NOTICE

**W.D.H.V.C. MEMBERSHIP FEES ARE DUE BEFORE 31<sup>st</sup> MARCH.**

Enclosed with your printed *Backfire* (and posted to email *Backfire* recipients), is a yellow membership form, which **must be filled in and received by the W.D.H.V.C. with your membership fees before 31 March 2016.**

Please complete the yellow form and we will be collecting your forms and money at the **8 March meeting from 6.30pm to 7.30pm**, before the meetings.

**NO MONEY WILL BE ACCEPTED WITHOUT A COMPLETED YELLOW FORM.**

**If you have Red Plates registered with our club, and we have not received your completed membership form and money by 31<sup>st</sup> March 2016, you will be no longer be eligible to drive your Red Plated vehicle.**

If you no longer wish to be a member, please either email or post your resignation to our Secretary, Fred Harris, as we have a long waiting list of people wanting to join our club.



*AgVantage UAV* is a new business that uses computer-controlled drones to take detailed images of farmer's fields. The drones fly a grid pattern over the land and the overlapping images quickly show any areas of 'crop stress', allowing for a precision assessment, the most appropriate solution for any issue found, and increased yields and profit margins.

The images can detect any problems up to two weeks earlier than the human eye. Using the low flying drones can give the farmer critical data more cheaply and quickly than satellite or aeroplane based alternatives. The farmer has the imagery of his crop or field within 24 hours of *AgVantage UAV* being on farm. This enables the farmer or his agronomist, to go directly to the GPS coordinate of a suspect area and take a soil sample or plant tissue sample. Quite often these are not easily seen from the ground. This method enables preventative treatment (eg. fertiliser, fungicide or herbicide) to be applied sooner, and only to the areas that need attention, saving dollars and increasing yield.

The system helps to identify germination rates ; areas of plant stress; soil constraints - shallow, salt or drainage; nutritional or irrigation deficiencies; non-wetting areas; soil and fungal disease (of foliage or roots); insect damage; low organic matter zones, and sand hills. It can identify harvest zones for improved grain grades and profit.

Two types of images can be produced - NDVI (Normalised Difference Vegetation Index) and/or High Definition digital color. All plants both absorb and reflect radiation in the near infrared band. There is a specific color range that indicates a healthy plant. Outside of this, is a plant 'under stress' and NDVI imagery can identify those problem areas.

*AgVantage UAV* has CASA (Civil Aviation Safety Authority) approved licences to operate UAVs (Unmanned Aerial Vehicles) commercially for any industry or business within Australia. Its aircraft, which the firm has designed and built from the ground up, are designed to assist farmers and agricultural consultants to improve or aid their farm management decisions in a timely and cost effective manner.

The firm has a strong practical background in precision Ag systems and farming. Its goal is to build relationships with key stakeholders in agriculture and to gain a reputation as the UAV AG experts, with a focus on clients' needs, striving to help clients achieve their goals and work towards a more sustainable way of farming.

- Taken from notes provided by February meeting guest presenter, Joshua McLeod.

# The World's Worst Cars?

This is a new addition to our *Backfire*, taken from the book *The World's Worst Cars* and is only a bit of fun to add to our magazine. Please don't take offence if your car features in this segment in the coming months. - Libby Booley

As taken from the *Worlds Worst Car's*  
by Craig Cheetham

## **BADLY BUILT CARS.**

DATSUN 120Y (1974 -78)

Specifications.

Top speed: 145KM/H (90MPH)

0-96KM/H (0-60MP/H) 16.0SECS

Engine Type: IN-LINE FOUR

Displacement: 1171CC (71CI)

Weight: 791KG (1757lb)

Mileage: 8.3L/100KM (34MPG)

The 120Y-also known as 'Sunny'- put Japan's fledgling motor industry on the map, racking up an astonishing number of sales: 2.4 million across Europe and America in a four-year production run. It did this by offering value for money and generous specification levels. Despite the model's early promise, however disgruntled owners discovered in later years that the car was far less good a package than they first thought.

While the 120Y was mechanically almost unbreakable, it soon became apparent that the Japanese weren't very good at rust-proofing, and the car acquired a reputation on the second-hand market as something of a rot box, with rust eating its way into the sills, boot (trunk) floors, firewalls and sub frames faster than a plague of woodworm in a timber yard.

It did, however, have striking and intricately styled stainless-steel hubcaps. This may not have been much of a saving grace, but if Datsun's designers had spent as much time styling the car as they evidently did the wheel trims, they might have had a winner on their hands.

Instead they created a car that was ungainly from almost any angle, especially if you opted for the station wagon, whose rear load area was welded on almost like an afterthought.

The 120Y was a fairly successful rally car, but its poor handling could catch out even the most skilled of drivers on bad surfaces.

## **120Y: A Lesson in Design Failure**

It looked attractive in the brochure. The Datsun had a radio, a heater, reclining seats and a heated rear window as standard – but, though good value, it felt cheap and was poorly finished.

Datsun offered a truly revolting two-door coupe version of the 120Y- a car so hideous that it has an almost cultish appeal today.

The Datsun's structure was simple, with leaf springs at the rear and independent front suspension. It made for predictable handling on dry roads, but it could be uncomfortably twitchy in the wet.

Structural problems didn't take long to make their presence felt, and the sills, floor pans and rear sub frames were often the first parts of a 120Y to see the business end of a welding gun.

## **Japanese Rust Bucket.**

Although the 120Y was mechanically reliable, the overall package was disastrous, as rust and rot took hold and the bodywork started to disintegrate before its owner's eyes.



# CALENDAR OF EVENTS

## WDHVC EVENTS

### 28<sup>th</sup> FEBRUARY - SUNDAY

### LADY'S LUNCH

A chance to give a little something back to the wonderful Ladies who both voluntarily and involuntarily help keep this club ticking!

\* Assemble at the clubrooms from 10am for a meet and greet with a cup of tea, and some light morning tea.

\* Short drive to the botanical gardens for a gentle wander, chauffeur driven.

\* Short drive to a mystery destination for a delicious lunch, coffee and cake.

\* Guest speaker, and door prizes.

No need to do a thing, everything supplied and organized, please sit back and enjoy!!

Gentlemen will be entertained at the residence of President John Bailey.

BBQ and soft drink supplied, and maybe some fairy bread.

#### **What I need:**

LADIES ATTENDING Numbers for catering, please put your name down at the February meeting, contact Sean on 5298 1476 or via email [spelmurphy@hotmail.com](mailto:spelmurphy@hotmail.com)

GENTLEMEN ATTENDING Chauffeur drivers please with a reliable classic/vintage cars with four or more spare seats, need 10 cars/drivers minimum all makes and models, numbers for the BBQ.

### 6<sup>th</sup> MARCH - SUNDAY

### SEASICK RALLY

It is our turn to host the Mornington Peninsula Club so we will require cars to transport them around . They will arrive at the Queenscliff Ferry Terminal around 9.45am: please be at the Terminal by 9.30am. Bring thermos's of hot water, a plate of morning tea, cups and extra chairs (so they don't have to carry chairs on the Ferry). Please consider this Rally if you have not experienced it before as it is a great way to meet fellow car enthusiasts. It's always enjoyed by all participants. Call Cheryl Elliot on 5248 0734 for more information or to put your name down.

### 9<sup>th</sup> MARCH - WEDNESDAY

### DINE OUT

Bannockburn Hotel, 6.15pm. Put your hand down the back of the couch, find a dollar or two and join us. Thank you to all (30) who came to Drewan Park for a picnic tea – a lovely evening.

Gary 5275 2544 or 0427 752 544.

### 10<sup>th</sup> March - Thursday

### SHEARING SHED ON WHEELS—final inspection

10am Clubrooms start. John Bailey has invited us to see his pet project in its final stages of manufacture. The only stipulation is, please do not take photos of the project, and we need to be out of his hair by 1pm so that he can get on with his work. BYO everything for lunch.

Contact John Bailey 0413 258 302.

### 19<sup>th</sup> March - Saturday

### SMELL THE ROSES DAY

Another 10.30am Start from the clubrooms. I will be looking for one of the riders to lead us astray on that day. I have no particular destination in mind other than maybe a coast run to Bells Beach or Anglesea or anywhere else that suits us, that has a café.

### 24<sup>th</sup> MARCH 2016 - THURSDAY

### FORD FACTORY VISIT.

Numbers limited to first 30 on list. There will be no need to start from the clubrooms. Meet at the North Shore Rd entrance Fords car park at **9am sharp**. There will be lots of parking for our cars!

For those lucky people that are going , there are a few Health and Safety requirements to meet or **they will not let you in**. We, including the ladies, must wear **long pants, long sleeved shirt, and fully enclosed footwear**,. No open toed footwear allowed. These rules apply to all people who enter the Ford factory.

Ray van Galen Ph 5278 9368

## 9<sup>th</sup> & 23<sup>rd</sup> APRIL - both SATURDAYS    **WORKING BEES**

From 8am at Clubrooms. Painting exterior. Bring your brush or roller. Morning tea & lunch provided.

### 17<sup>th</sup> APRIL - SUNDAY

### **HOT DOG RUN.**

Assemble at the clubrooms at 10am for a mystery destination. Fred to lead the way. Numbers of people attending and whether they require 1 or 2 hot dogs to be put on list at the March meeting. Club will supply hotdogs, bread, sauce, cake, and hot water. You need to bring your own cutlery, plates etc. If you don't like savs but would like to do the run please come along and BYO. Ph. Graham on 5243 7757 or 0417 559 622 for more details.

### 25<sup>th</sup> APRIL - MONDAY

### **ANZAC DAY.**

A breakfast run - nothing planned as yet.

### 22<sup>nd</sup> May - SUNDAY

### **OBSERVATION RUN.**

Set to bring back a little fun to the club. Assemble at the clubrooms from 10am. 50km mystery run, with points and items to collect along the way, culminating in afternoon tea at the clubrooms, along with prize draws. BYO packed lunch to have along the way. Concerns raised considered and allowed for. Contact Sean on 5298 1476 or via email [spelmurphy@hotmail.com](mailto:spelmurphy@hotmail.com) for details - but no secrets given!

## JULY

## **PRESIDENTS RUN**

## **OTHER CLUBS EVENTS**

### 20<sup>th</sup> MARCH - SUNDAY

### **HIGHLAND GATHERING**

Goldsworthy Reserve Corio. Relocated due to Deakin works. Family \$40. Adults \$15. Concession \$10. Kids (5-16) \$8.

### 27<sup>th</sup> MARCH - SUNDAY

### **DEANS MARSH FESTIVAL**

10am - 5pm [deansmarshfestival.com.au](http://deansmarshfestival.com.au) Classic or Moderns. Meet at the Waurin Ponds Hotel car park, beside BP service station, for a 9am departure.

### 16<sup>th</sup> APRIL - SATURDAY

### **ECHUCA SWAP MEET**

Echuca Swap Meet, Rotary Park, Rose St Echuca. Automotive parts & collectables welcome. Display area for show & shine vehicles. 200 plus sites available at \$20 per site. On site catering. \$5 per person entry. Children under 15 free. Gates open: *sellers* 5am; *buyers*: 7am. **Enquiries:** 0456 010 665, E: [echucaswap@outlook.com](mailto:echucaswap@outlook.com) 10% of profit to a local charity.



### **Working be at club rooms**

There will be a working bee on the 9<sup>th</sup> and 23<sup>rd</sup> of April at our club rooms, starting at 8am.

This is to clean up and paint the exterior of the building and a few jobs inside.

Bring along a paint brush and roller if you have one.

Morning tea and lunch will be supplied.

we would like to see as many members as possible on those dates so, if you can spare a couple of hours, please come along.

### **Red Plate Holders**

Just a reminder to process your permit **BEFORE IT EXPIRES, OR A ROADWORTHY WILL BE REQUIRED.**

Also if you have changed your red plate from WDHVC over to another club, **please** contact Gus Shea, so he can remove you from our WDHVC red plate register.

We want our members to enjoy every minute of their vehicles and don't want any disappointments, as there are 12 fabulous runs coming up.

Happy Motoring!



# FEDERATION REPORT

## Public liability

All events attended by club members should be noted, to fulfil the requirements of public risk cover.

Golden oldies tour held in 2015 was very successful. This year and other seven-day touring event will start from a wrong picnic and travel to Mildura.

The 2016 the Marong picnic will alter. Members of Federation clubs will be permitted free of charge; other entrants will have to pay an entry fee.

Bendigo Swap Meet. Agreement has been signed with the Bendigo club to organise the swap for the next five years, with the option of a further five years.

**Robert Shannon Trust.** Seven younger restorers received assistance from the trust to help with the restoration.

**Australia Day 2016.** Another successful event held in Kings Domain. The number of vehicles on display was down because of an assessment by the Premier's Department. Down to about 260 vehicles.

The Federation is looking for younger delegates who may be prepared to progress to Federation committee at some stage.

The picnic at Mortlake will be held on 20 March.

National historic motoring day this year is on 15 May.

Next Federation meeting in Shepparton on 13 February.

## Coming events

20 March Federation Mortlake picnic.

15 May national motoring day.

12 and 13 November Bendigo National swap meeting.

# NOTICES

## TECH NIGHT

On **Tuesday 23<sup>rd</sup> February**, we will have a Tech Night in the workshop at the club.

This coincides with the Craft Night, as some of our ladies say they would come to Craft Night if their "Other Half" could come with them.

The ladies have a lot of fun (and gossip), and the more the merrier. Shirley Kaub and Cheryl Elliot do a great job running these nights, and I feel they need some support.

As their "Tea Lady", I speak with firsthand experience of the fun they all have.

Tech Night will be on gearboxes. You are invited to bring one or more gearboxes, or parts of gearboxes. I will bring an assortment of Willys gearboxes, including an Warner T96 overdrive, and my Borg Warner T5 to Willys conversion. Dallas Jones will bring a cut away T5.

If you have a Laycock de Normanville overdrive, or a Wilson Pre Selector, or a Moss, or a T Ford, or any other box, under your bench, please bring it, or them. Bell housings, Floor Shift Conversions, or anything to do with gearboxes (including broken parts) would be welcome.

This will be a trial, and the more we all put in, the better chance of this event has of succeeding.

If we all turn up around 7pm, we should be ready to get started around 7.30.

- Peter Telfer

## **Changes for Backfire cut off date and folding date**

Cut off date for the articles will be the Friday after the 3<sup>rd</sup> Tuesday of the month.

Printing date to be 4<sup>th</sup> Monday of the month. Folding Backfire date to be 4<sup>th</sup> Tuesday of the month.

Items for the next edition of *Backfire* may be emailed to: [editor@wdhvcgeelong.com.au](mailto:editor@wdhvcgeelong.com.au)

## For Your Workshop.

*Electric motors are more reliable and require less maintenance than internal combustion motors, but they still break down. Before attempting to repair a motor, turn off the power and pull out the plug. Most electric motors in the workshop are of four types.*

**Series Motors** with carbon brushes. These are used in electric drills, power saws and garden tools etc. The carbon brushes wear and can be replaced with external screw in brush holders. However with internal brushes the motor has to be dismantled for replacement. Carbon brushes come in all different sizes and getting the correct one may be difficult. However the more likely failure is the off/on switch with the contacts burning out. Power tools have special switches and the manufactures switch will be needed for replacement, which may be very difficult to get. Some switches are double pole switches, switching both the 'Active' (brown) and the 'Neutral' (blue). A temporary repair is to bridge the faulty switch, but this will fail soon also. On non-portable tools an external switch can be used.

**Capacitor Run Motors** are used fixed machines such as drill presses, compressors, pumps etc. Capacitor run motors are simple in construction but have low starting torque. The motor current increases with load, when the motor is running less than the rated speed due to heavy load or on starting with a load. This results in more current flowing through the windings and the capacitor. This generates heat in the motor and the capacitor.

The most common fault is the capacitor failing. Inspect original capacitor, any with bulges or leakage, they need to be replaced. Some capacitors fail without any visual sign, measure the insulation resistance with a digital multimeter or measure the Capacitance with a digital meter on a capacitance range (more expensive meters) or substitute a suspect faulty one with good capacitor. If the motor is not starting or starting slow then check the capacitor and the motor winding resistance. Capacitors can be purchased

cheaply on eBay. The replacement capacitor should be replaced with one within 10% of the manufacturer specification. The size is printed on side.



## Electric Motor Repair.

**Split Phase Motors** with an internal centrifugal switch that turns off power to the start winding when the motor gets up to speed. Capacitor run motors now have replaced these motor except in the larger motors. The most common failure with these motors is the start winding burning out, and rewind is usually not economical.

**Capacitor start and capacitor run motors** are a combination of 2 and 3. These have a larger capacitor in series with the centrifugal switch and the start windings for starting. Another smaller capacitor in series with the start winding is used to add a little extra power when the motor is running.

All these motors have a large surge current on starting. The current is much larger when the motor is starting than when it is operating at its rated speed. Also when the motor is fully loaded the current drawn by the motor increases which generates extra heat in the components and can cause them to fail.

### How to get best service life from the motor

1. Do not overload the motor.
2. Try and start the motor with no load.
3. Avoid repeated starts with heavy load.
4. Air Compressors: start air compressor with the off/on switch on the compressor, not the power point. The compressor switch bleeds air out to reduce the starting load.
5. Water pumps: these start with no load but quickly get to full load. Avoid repeated stop starts. Fix leaking taps etc.

If the motor fails again, check the load on the motor, measure the current drawn by the motor under load. Measure the current drawn by the motor using a clamp meter or a power meter. A power meter can be purchased from hardware shops or Jaycar Electronics and measures volts, amps, watts and kWh (electrical energy as sold to you). The meter plugs into the power point and the appliance plugs into it. Compare the wattage used to that on the label.

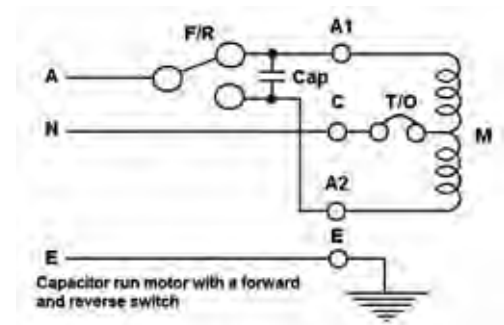

## **RALLY REPORTS**

### **WATERFRONT CAR DISPLAY**

What a great day sitting and wandering around the market at the Festival of the Sails, down on the beautiful Geelong Waterfront in front of the old Customs House.

We had 29 cars on display and the weather was kind to us, not too hot! A great variety of cars was on display and we had a huge crowd of people come and have a look over the cars.

We also had a large number of motorbikes gathered near the footpath for us to wander through and admire, for some of the mornig which was an added bonus for those of us that love motor bikes.

The only mishap for the day was a mobile phone slipping down the crack between the planks, but our men soon got to work and retrieved it again for the very thankful owner.

Thank you Sean and Gary for organising this great day for our members to enjoy.

- Libby.



**Who lost their phone down the crack in the boards at the Waterfront display? Lucky we had a carpenter in our midst to remove the board to retrieve the phone wasn't it Jeanette!!!!**

### **LAST MONTH'S SMELL THE ROSES REPORT**



We were in no rush to do a lot of miles on the day. We just wanted a short ride and a good coffee at Portarlington - and it was good too. The good people walking around at Port were amazed at the old Indian of Manual, and the leaky old Matchless got a looking at as well, with the usual "My uncle rode one of those after the war".

Present on the day were, Manny Vella, Ray van Galen, Richard Anderson (BMW K75); Mick Wright (Ducati 906); and Dallas Jones (BMW R series). Helen and Graham Cameron came along in a car.

Great weather, good company and a lovely ride.

That is as good as it gets. - Ray van Galen.



### **CANCELLATION OF RALLIES ON DECLARED TOTAL FIRE DANGER DAYS**

The Club Committee recently reviewed the practice of cancelling or postponing rallies that involve the driving of historic vehicles on declared fire danger days. Members are advised that the policy of cancelling Club events involving the use of historic vehicles on declared total fire danger days, will continue to apply. Obviously other Club functions (such as general meetings) not necessitating the use of historic vehicles, can still be held.



# RALLY REPORTS ctd

## AUSTRALIA DAY

26th January Australia Day at Rippleside Park.

We fronted up at about 10am to be met at the gate by Big Frank, who told us where to park.

We were down near the water and it was a good spot.

About 12 cars turned out, which made Ken Parker's day as he had organised it for the Museum.

We have never been to an Australia Day picnic and were most surprised at the amount of people and activities for every taste.

Food was abundant and there were free rides for the kids.

All in all a most pleasant day: we will go again.

Thanks to Ken Parker for the invitation.

- Sharyn and Fred

## "Heard of a Bradford?"

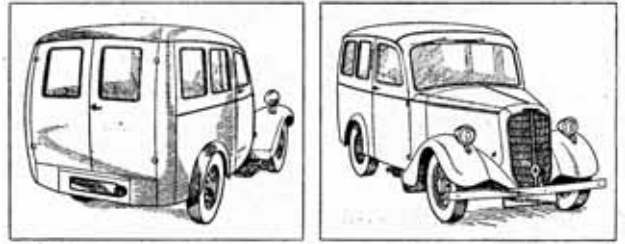

In the (February) "Backfire" I noticed a heading "Heard of a Bradford?".

Well - "Yes I have".

In 1951 when we moved to "Mawallok" - a very large property approx 11 miles south of Beaufort. My father, as part of his many duties, used a mighty Bradford to collect milk from a neighbouring farm each day. In the winter the mighty Bradford went in reverse gear up a very muddy track. Each month my father would fit 4 seats into the back to take the ladies into Beaufort to do their shopping. (We had a Ford 10 Panel van and the owners of course had vehicles but not the working class.)

So my father and five ladies headed to Beaufort. However there was a long winding steep hill- again which the mighty was placed in reverse and one of the ladies had to get out and advise my father of any cars etc. coming the other way. There were also times my mother had to sit on the mud-guard with a bottle of petrol to tip into the carby as my father thought going up this nasty hill forwards might be better for the ladies ( not my mother of course)

Can you imagine the amount of shopping that had to be squeezed into the mighty Bradford?

That heading reminded me so much of my early childhood, and of course of the mighty Bradford (my father of course had other names for it that mother wasn't to hear!). Thanks for the memories - Gary



Western District Historic Vehicle Club Inc.

Don't miss it - Put it in your diary now!



### GEELONG BAY CITY SWAP MEET

**Saturday May 14th, 2016**



Geelong Showgrounds  
Melway Ref 452 E10



Plenty of room for displays Bargains for motorists, restorers, collectors, craft enthusiasts, DIY mechanics etc.

**7.00 am Start**

Admission for Adults \$5 -- Children free

Outdoor Sites (10m x 6m) \$10 plus \$5 admission charge  
(No booking required for outdoor sites)

\* Area for display and sale of Special Interest Vehicles\*

Overnight camp sites available, for stallholders only

Food available on Friday evening from 4.00 pm to 8.00 pm  
Geelong mobile ATM facilities available on site

Telephone enquiries - 0417 546 089  
Mail enquiries- WDHVC Box 200 Newcomb Vic 3219

STRICTLY NO DOGS ALLOWED IN SHOWGROUNDS  
NO FIRES PERMITTED NO UNAUTHORISED FOOD VENDORS  
NO RIDING OF SKATE BOARDS, BICYCLES, MOTOR BIKES OR  
RECREATIONAL VEHICLES IN SHOWGROUNDS

**PARKING FOR NON -SELLERS WILL BE IN THE  
RACECOURSE ADJACENT TO THE SHOWGROUNDS**

**Economy Champion of All Time . . .**

**THE NEW FIAT 500c 'Nippy Seven'**

All the important time-proved features of the popular Fiat 500B, plus many more, are incorporated in the new Fiat 500c "Nippy Seven" for T.W.O. 50/50 n.p.g., independent front wheel suspension, hydraulic brakes, internal heating and ample luggage room, are but few of the outstanding features. Take delivery of your 4 cylinder 500c Coupe or Convertible today!



50/60 M.P.G.

**Also FIAT "12" & "16" (6 Cyl.)**

**All-Imported Pillarless Saloons For Immediate Delivery**

Sole Distributors for Victoria, Southern Riverina and Tasmania  
**DEVON MOTORS PTY. LTD.**  
117-121 LONSDALE STREET, MELBOURNE. Phone JM 1577.



# WDHVC MEMBER PROFILE



**Name?**

Pam

**Where were you born?**

Geelong

**Family?**

Husband Gus, 2 daughters 2 grandchildren

**Number of years in the WDHVC?** ???

**Other interests?**

Just retired, travelling, cooking, going to shows, sewing and gardening.

**What was your first vehicle?**

Mazda Capella

**What vehicle would you love to own?**

Bobcat to clean up the junk in the shed

**What vehicles do you have now?**

Convertible Ford Capri

**Profession?**

Administration

**Skills?**

Looking after grand children

**What bugs you the most?**

Bad manners

**What makes you happy?**

Glass of wine, holidays, travelling, site seeing, grandchildren, being healthy.

## Mars Bar Competition The March competition.



Now Sis, when you get to the Hills hoist, take a hard left and make sure to avoid mums washing basket and try to beat my lap time, OK? Who is this member? Did he continue with a career in the driver education field, perhaps in the RACV or did he repair Hills Hoists for a living. I feel he could have ended up being a pedal car salesman. Find out this and more in our next general meeting where the huge mars bar awaits for the correct answer.

### THE LAST GREAT MARS BAR COMPETITION.

For some reason or another, no one worked out that it was Graham Peacock in the photo after I practically said it was to do with politics, maybe. We used to have an Andrew Peacock in politics once upon a time as I recall. Graham got to have the Mars Bar all to himself.

*Ray van Galen. Ph 5278 9368*

The views/comments expressed in the publication of this newsletter are those of the individual contributor and are not necessarily endorsed by the current Committee of the Club. Whilst every care is taken to determine the safety of any technical information provided and the accuracy of the information supplied for inclusion in this newsletter, it is printed in good faith and neither the Committee nor the Club accept any responsibility for any loss or injury incurred by any application of such information.

## February Tinker Day Report

We gathered at the clubrooms on a gloomy looking start of the day but it did not rain, and off we went to the State Emergency Service in Furner Ave North Geelong. Once we were all parked, we were greeted by our host Ian Carlton, one of the very knowledgeable SES workers. Ian's job keeps him on his toes and wondering where he will be sent and what emergency has occurred there.



We had lots of questions for him and we are much better informed about the good work of the SES now thanks to Ian.

Then it was off to have a quiet picnic lunch at the van Galen's and have a gander at the progress of the old motorbike restoration in the shed. Ken Sheppard was also presented with Ray's spare left lower prosthetic leg to hang up in his memorabilia shed, just for a lend as he may need it later.



All in all a very interesting day.



## SALES, WANTED & CLUES

### For Sale

**4 Michelin tyres** 195/85 R16" LT steel radial tubeless \$425 ONO.

Dunlop 750x17" 10 ply tube & rim tape \$85 ONO.

GEELONG black & white enamel plate \$25 N.O.S.

Chev complete water pump \$160.

4 pieces steel mesh reo 8' x 4' \$25.

Kevin Ph. 5248 3032.

3/16

**Mercedes Benz Alloy Wheels** Four 215/55R16" to suit 1999 model. Four 205/70R14" to suit 1974 onwards. all with tyres, some good. Make an offer. Correct phone for Barry Collinson 5259 3625.

10/15

**Mercedes 1983, sedan**, 123K series. Imported, 2 l, 4 cyl, white, 313,202 km. Excellent body, good upholstery. Registered to Mar 2016. Personal number plate DRTREV. RWC at about 300,000. Identical "cannibal" car for free. Asking \$6,000 ONO Ph 0428 393 465.

01/16

### Clues

**1990 Telstar TX5**, 2.2 Turbo, Good Tyres, Good Interior, No Rust, has oil in Coolant and No Rego. Graham Ph 5253 1230

01/16.

### Wanted

**Water pump and complete thermostat housing** for 1956 Daimler Conquest DJ250, series 2. Both pump and housing have outlets for heater and water heated manifold. Contact Ian Duncan on 5258 2861.

01/16

**1948 Ford Mercury** 3 speed gearbox column change.

**Army 6 wheel Studebaker truck** for sale.

Also person who rang me about **Morris J van wheels and diff** please contact Gus 0400 203 151.

01/16

For sale/wanted ads are free to Members and appear for two (2) issues of *Backfire*. To remove the advertisement from the second issue, please email the Editor '[editor@wdhvcgeelong.com.au](mailto:editor@wdhvcgeelong.com.au)'

**Reminder:** All vehicles in the "For Sales" must have VIN number and Price or Registration Number and Price otherwise they will be listed under "Clues". Ads for the 'Clues' section must not refer to any payment that may take place by mentioning an amount or 'best offer', etc.

**All ads that have been removed due to age will remain on the website. Please advise if you have sold the item or want it removed.**

All ads for cars also appear on the club web site where greater detail and photos (where supplied) can be viewed. Go to <http://www.wdhvcgeelong.com.au/wdsale.html>

If undelivered return to:  
 WDHVC  
 PO Box 200  
 Newcomb VIC 3219

**PRINT POST APPROVED**  
**PP 1000/19091**

BACKFIRE

POSTAGE  
 PAID  
 AUSTRALIA

# March/April 2016

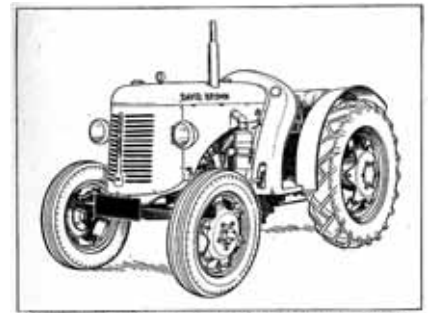

DISTINGUISHING FEATURES—Earlier models had single central headlights. On latest tractors "Cropmaster" appears on sides of bonnet top.

Sun	Mon	Tue	Wed	Thu	Fri	Sat
28 Feb Lady's lunch	29	1 March	2	3	4	5
6 Sea Sick Rally 9.30am	7	8 General Meeting 7.30pm	9 Dine Out 6pm	10 Shearing Shed on Wheels inspctn	11	12
13	14	15 Committee Meeting	16	17	18 Last day for <i>Backfire</i> items	19 Smell the Roses 10.30am
20	21	22 Folding <i>Backfire</i> .	23	24 Ford Factory visit. 9am	25	26
27	28	29	30	31	1 APRIL	2
3	4	5	6	7	8	9 (&23) Working Bee Clubrooms 8am